

# White paper

## Piston spool valves and poppet valves

### – Choosing the right solenoid valve technology

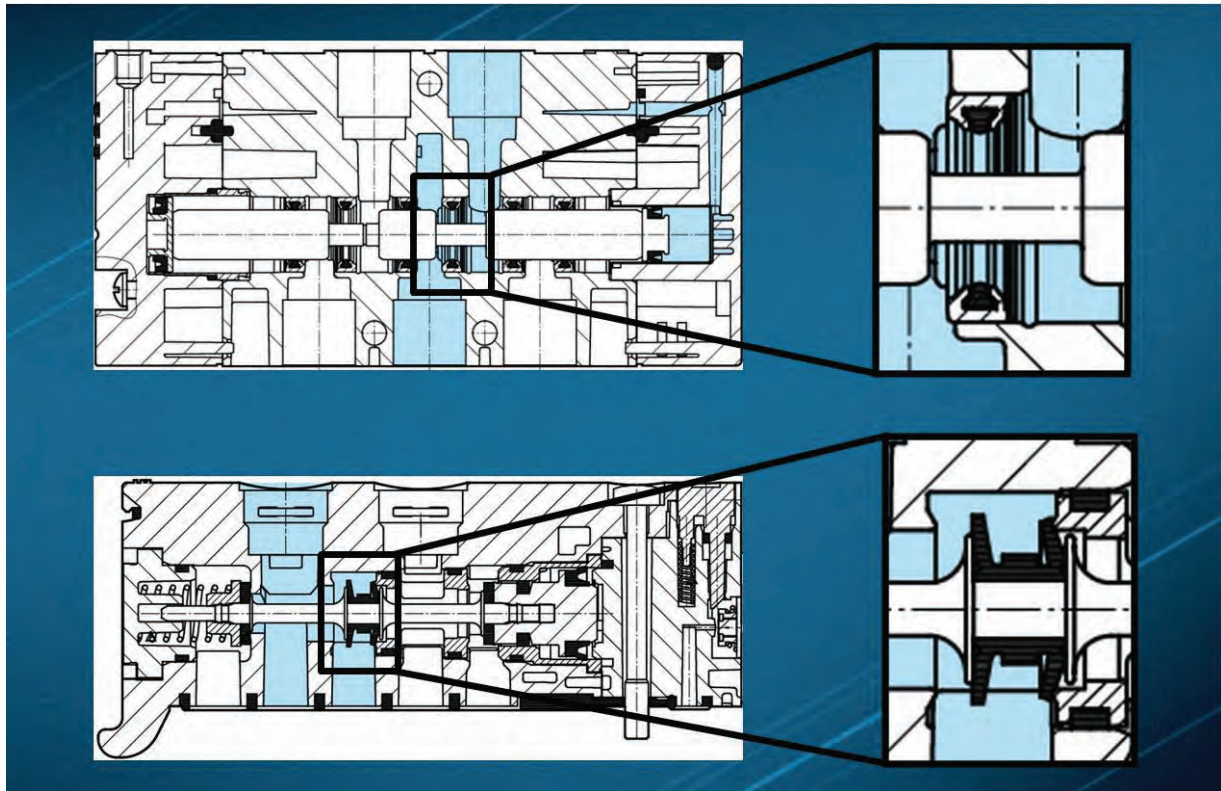

### Why should you choose your valves carefully?

The increasing demands placed on valve technology in recent years have led to a formidable extension of the range of available technologies and valve types, models, and properties. The most commonly used are poppet valves and piston spool valves. Nowadays, there is a much wider choice of customised valve technology to successfully plan a project. However, choosing the right parts for the application at hand requires comprehensive knowledge and an accurate appraisal by the consulting engineer or technician. This White Paper is intended to offer you a brief overview.



**Festo's Core Range**  
of products features next day delivery, great Festo quality and attractive prices. Look for the blue star in our catalogue.

[www.festo.co.uk/stars-valves](http://www.festo.co.uk/stars-valves)

## An introduction to valve technologies

Poppet valves and piston spool valves are the most commonly used valves for controlling compressed air. Flat slide valves, rotary slide valves, piezo valves and other technologies tend not to be used as often. The chart in figure 1 offers an example of how the two common technologies can be subdivided. Among the piston spool valves, the valves with a cartridge seal are particularly interesting. This type of valve has lower leakage values and offers significantly higher operating pressures.

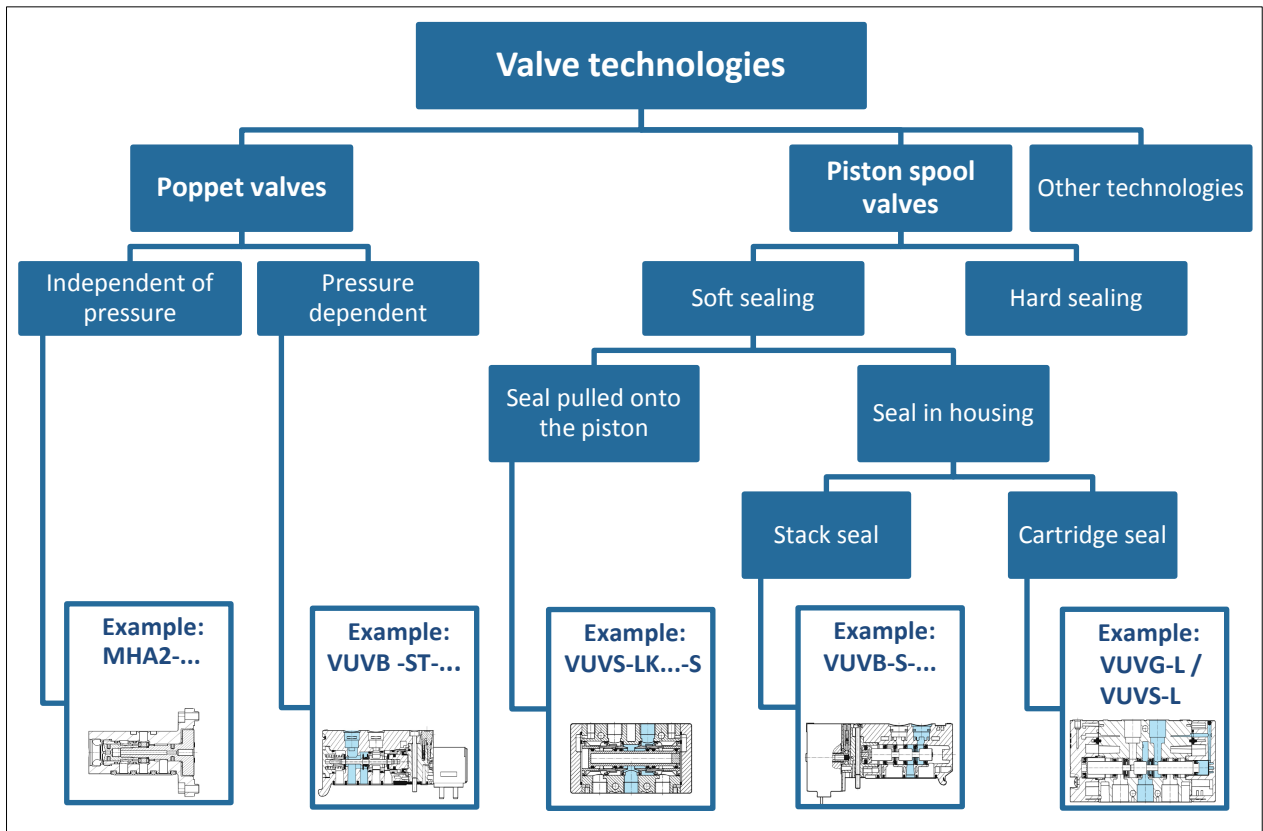

Figure 1: Examples of valve technologies

## Poppet valves, piston spool valves and the cartridge principle – what you need to know

### The poppet valve

The very simple construction and the option of using any material often makes poppet valves less expensive than the piston spool valves. For instance, a 5/2 poppet valve (see figure 2) only requires 3 axial seals, but there are additional advantages with this technology: the actuation strokes are small, which allows for shorter switching times. The axial sealing technology is resistant to soiling. Also, poppet valves do not require lubrication, which is an advantage in terms of chemical compatibility with lubricated compressed air.

The greatest drawback with poppet valves is the relationship between space and flow, due to constructional constraints. Poppet valves always offer a lower flow than slide valves, for a given width, when it comes to pressure-independent models. The reason for this is the greater structural demand – in pressure-dependent valves, the control pressure is dependent on the operating pressure.

This is because when the air flows through the valve, as seen in figure 2 from channel 1 to channel 2, the surface area  $D2$  is larger than  $D1$ . Since the same operating pressure is exerted on both surfaces, an imbalance of forces occurs, which has to be compensated.

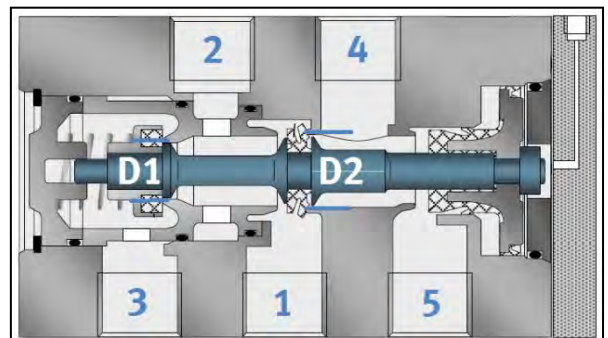

Figure 2: Pressure-dependent poppet valve

Furthermore, it needs to be noted that this valve construction is not always without overlap. Depending on the design, a change of switching positions can lead to overflowing between the channels. This gives rise to unnecessary leakage and noise.

### The piston spool valve

Whereas the actuation forces in poppet valves are relatively great, they are much smaller in piston spool valves, because the valves do not have to be switched against any forces generated by the operating pressure. The problem with overlap is also easily solved, as can be seen in figure 3.

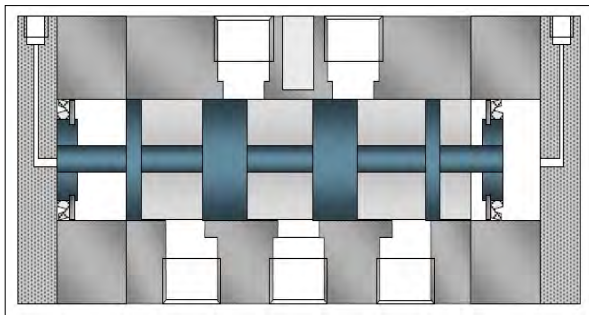

Figure 3: Piston spool valve

However, there are drawbacks with this valve type too. For example, the strokes for switching operating positions are longer than with poppet valves. These longer strokes and the placement of several pistons mean that the piston spool valves on the whole have to be longer. In terms of manufacturing, piston spool valves are also more challenging, particularly when it comes to sealing technology. Two categories have evolved in this area:

- **Category 1: Hard-sealing systems**

These sealing systems are more durable, but also more demanding. The durability is a result of the absence of soft rubber sealing elements in the piston spool valve. This means that valves using this sealing technology are immediately ready for full dynamic use even after longer periods of inactivity. In soft-sealing systems, there may be adhesive effects, which cause the sealing elements to wear out faster. The greatest challenge with the system is that the air gap surrounding the moving piston must not be larger than a few micrometres. A metal sleeve is often used, in which the valve spool moves. The sleeve then works both as a seal and as a guide for the valve spool. It is crucial that the sleeve and the spool are made with the same material, since different materials have different thermal expansion coefficients. If this is not taken into consideration, greater leakage will occur, and even jamming of the spool. The combination of the sleeve and the spool

therefore has to comply with many technical specifications, since even the smallest deformation in the housing, e.g., due to tightening of screws, can damage sleeves and affect the life and leakage values of the valve.

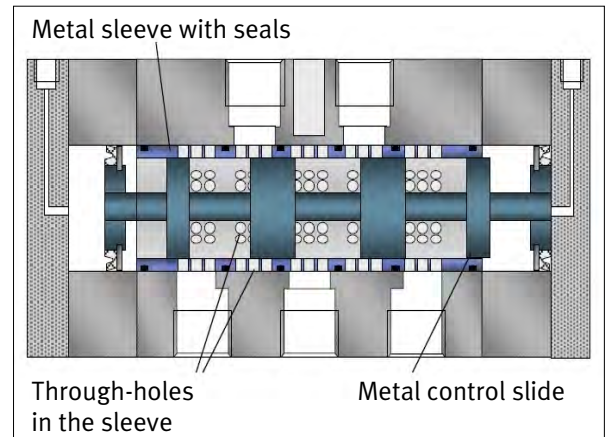

Figure 4: Hard-sealing system

In conclusion, hard-sealing systems are very robust and durable. The greatest drawback is that there is always a certain leakage with these systems because of the air gap. Furthermore, their flow capacity is lower than that of other valves with the same constructional dimensions.

- **Category 2: Soft-sealing systems**

A technical alternative to hard-sealing systems is to use rubber gaskets (O-rings or moulded elastomer seals) on the piston.

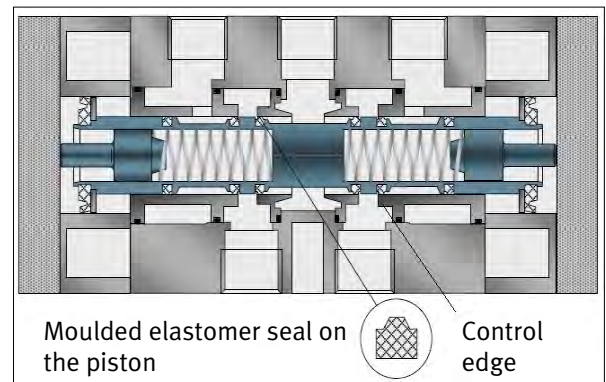

Figure 5: Soft-sealing system with gasket on the piston

The problem with this alternative is that the rubber gaskets may be worn down fast when in contact with the channel edge – the so-called control edge. The control edge must therefore be carefully designed, as only optimal planning of the control edge, the moulded elastomer seal and the piston guide can guarantee a soft passage with a minimum degree of wear.

There is, however, yet another alternative. As illustrated in figure 6, the seals can be mounted directly in the valve housing. This looks like a great option, but there are two disadvantages.

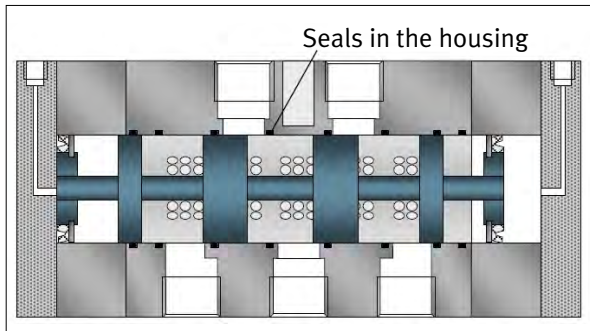

Figure 6: Soft-sealing system with seal in the housing

Firstly, the recesses required are difficult to produce and, secondly, the Bernoulli effect will cause the seal to be pulled out at a pressure of approx. 8 bar or higher. This again causes greater wear on the seal. Figure 7 shows the process in detail:

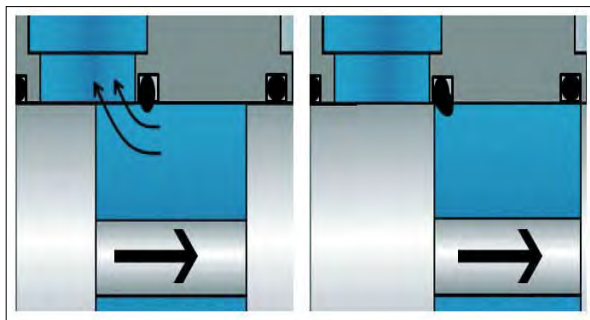

Figure 7: Increased seal wear due to the Bernoulli effect at a pressure of approx. 8 bar or higher.

1. The high pressure and the restriction of the channel produce a higher air flow rate through the valve.
2. The pressure in the valve is reduced due to the increasing air flow rate.
3. The greater static pressure on the groove base forces the seal slightly upwards.
4. When switching positions, the valve is squeezed harder and is potentially worn faster.

- **The cartridge principle for piston spool valves**  
One solution to the problem described in figure 7 is to use moulded seals in metal cages. The seals are thus retained in recesses in the metal housing; the so-called cartridge principle (figures 8 and 9).

The advantage with this solution is that the seal will not be pulled out of its position even at an operating pressure of up to 16 bar, thanks to the recesses in the metal cage. This ensures a significantly longer valve life. In addition, the quality of the sealing between the piston and the elastomer seal is good enough for the cartridge principle valves to be used for vacuum operations without any problems.

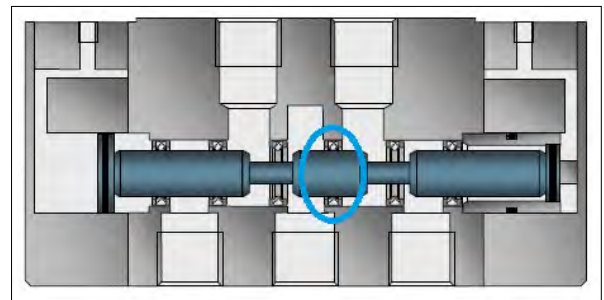

Figure 8: Piston spool valve with cartridge principle

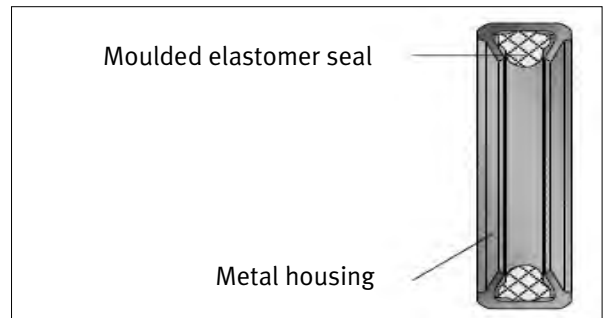

Figure 9: Cartridge seal

## Which valve type suits you best? A valve selection aid

Both valve types; piston spool valves and poppet valves, come with their advantages and disadvantages. However, if you are looking for a type of valve with low leakage values and the option of dual-pressure operation<sup>1</sup> with vacuum and ejector pulse, or if you require high operating pressures, the most suitable is probably a piston spool valve with cartridge sealing technology.

	Piston spool valve (seal on piston)	Piston spool valve with cartridge principle	Conventional poppet valve (pressure- dependent)
Relationship between valve size and flow	++	+++	+
High operating pressures up to 16 bar	Not available	+++	++
Vacuum operation	++/+++ <sup>2</sup>	+++	++
Reverse operation	++	+++	Not available
Resistance to "polluted air"	++	++	+++
Low leakage values	++	+++	+++
Switching time	++	++	+++
Lubricant compatibility <sup>3</sup>	+	+	+++

Table 1: Valve selection aid

+++ = Excellent  
 ++ = Good  
 + = Satisfactory

### Festo Ltd

Applied Automation Centre  
 Caswell Road  
 Brackmills Trading Estate  
 Northampton  
 NN4 7PY  
 Phone 0800 626422  
 Fax 01604 667001

E-mail: [info.gb@festo.com](mailto:info.gb@festo.com)

[www.festo.com](http://www.festo.com)

1) Pressure-compensated poppet valves may also be used for dual-pressure operation.

2) Depending on the structural design.

3) If lubricants are used when working with compressed air, this will hardly affect the poppet valves, as their operation is usually "dry". However, in piston spool valves, chemical processes involving the lubricant may occur in the valve.